



MAZDA 2016 MX-5 : ND5RC

CUSCO USA EDITION

SUSPENSION COILOVER KIT

SUSPENSION PARTS

LSD • CLUTCH

STRUT BAR • CHASSIS BRACE

ENGINE PARTS

SPORT EQUIPMENT • EXTERIOR PARTS

MAZDA NEW ROADSTER [ND5RC] HIGH PERFORMANCE PARTS



www.cusco-usa-inc.com



- Full height adjustable coilover structure
- 24 way adjustable needle valve shocks
- Mono-tube shocks
- Front: HD rubber upper mount
- Rear: HD rubber upper mount

MONO-TUBE SHOCKS

24 WAY ADJUST

Street Spec.

MONO-TUBE SHOCKS

24 WAY ADJUST

Circuit Spec.

- Full height adjustable coilover structure
- 24 way adjustable needle valve shocks
- Mono-tube shocks
- Front: pillowball upper mount
- Rear: pillowball upper mount



Full height adjustable coilovers for a wide range of setting

- Fixed dampening shock absorber
- Full height adjustable coilover structure
- Equipped with top upper mounts
 - Front: pillowball camber adjustable
 - Rear: HD rubber upper mount
- ★ **Optional**
 - Front and rear pillow upper mount version kit avail
- * **Pillow ball upper mount (option)**
 : Price + \$400.00 (Front & Rear)



Adjustable for comfort at any driving stage

- 40 way adjustable needle valve shock absorber
- Full height adjustable coilover structure
- Equipped with top upper mounts
 - Front: pillowball camber adjustable
 - Rear: HD rubber upper mount
- **CPRV Valve (Corrective Pressure Regulating Valve)**
 Pressure dependent valve = comfort & stability
- **ECon2 Electronic Damper Control Unit compatible**
- ★ **Optional**
 - Front and rear pillow upper mount version kit available



Pillow ball upper mount

Designed to use with ID65 straight cut coil springs.
 Front : Part # 429 411 A65 : Price \$320.00 (pair)
 Rear : Part # 429 421 A65 : Price \$320.00 (pair)



* Pillow ball upper mount (option)
 : Price + \$400.00 (Front & Rear)



Street Series Adjustable Suspension Coilover Kit



NEW LOW PRICE



* E-Con2 available (option)
 Part # 00B 60J 1010 : Price \$634.00
 * G-sensor available (option)
 Part # 00B 60J G : Price \$131.00



TYPE	UPPER MOUNT Fr / Rr	DAMPER	REFERENCE HEIGHT	PART NO	Price :	RECOMMENDED HEIGHT FRONT/REAR	MAXIMUM HEIGHT FRONT/REAR	SPRING RATE (OPTIONAL RATES)		CP3 OPTION UPPER MOUNT - FR/RR	ECON2 NOTES
								FRONT	REAR		
Street ZERO	ARG / ARG	Fixed	-40mm/-40mm	429 61P CN	\$1,220	-50~0mm/-50~0mm	-108~0mm/-76~0mm	6 (5,7,8,9)	3.5 (3,4,5,6)	PRG / PRG	-
Street ZERO	PRG / PRG	Fixed	-40mm/-40mm	429 61P CP	\$1,520	-50~0mm/-50~0mm	-108~0mm/-76~0mm	6 (5,7,8,9)	3.5 (3,4,5,6)	-	-
Street ZERO A	ARG / ARG	40 way	-40mm/-40mm	429 61N CN	\$1,500	-50~0mm/-50~0mm	-108~0mm/-76~0mm	6 (5,7,8,9)	3.5 (3,4,5,6)	PRG / PRG	○
Street ZERO A	PRG / PRG	40 way	-40mm/-40mm	429 61N CP	\$1,800	-50~0mm/-50~0mm	-108~0mm/-76~0mm	6 (5,7,8,9)	3.5 (3,4,5,6)	-	○
ZERO-3S	ARG / ARG	24 way	-40mm/-40mm	429 63S CN	\$1,980	-50~0mm/-50~0mm	-82~0mm/-81~0mm	8 (7,9,10,11,12)	4 (5,6,7)	-	-
ZERO-3R	PRG / PRG	24 way	-40mm/-40mm	429 63R CP	\$2,280	-50~0mm/-50~0mm	-86~0mm/-84~0mm	12 (9,10,11,14,16,18)	8 (6,7,9,10,12,14)	-	-

ARG: Fixed camber hard rubber upper mount

PRG: Camber fixed pillowball mount

CP3 Option: \$400

*Please set vehicle height responsibly



FOLDING TOW HOOK : FRONT / Part # 429 017 F : Price \$131.00 : **: REAR** / Part # 429 017 R : Price \$131.00



Front : 4996338051981 Rear : 4996338051998

SWAY BAR : FRONT / HOLLOW 24 MM - Part # 429 311 A24 : Price \$ 334.00 : 4996338062178 * Weight : 3.55 kg / 7.85 lbs



150% stiffer rate than OE front sway bar

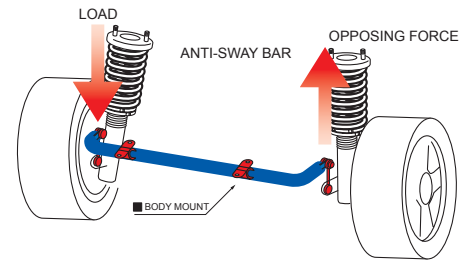

SWAY BAR : REAR / SOLID 14 MM - Part # 429 311 B14 : Price \$ 267.00 : 4996338062185 * Weight : 1.5 kg / 3.3 lbs

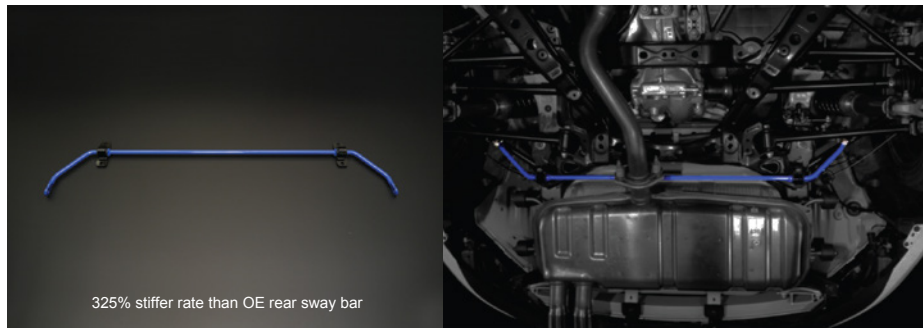

325% stiffer rate than OE rear sway bar



STRUT BAR : FRONT / 3 POINT TYPE-OS - Part # 429 540 AT : Price \$ 267.00 : 4996338429193



Lightweight aluminum oval shaft, strong & durable

QUICK RELEASE LEVER
 (2 pcs PER SET)

Enables quick removal of the strut bar center shaft without any hand tools.

Replace strut bar nut & bolt set for OS type.
 Part # 00B 540 C : Price \$54.00 (pair)



STRUT BAR : REAR / TYPE-OS - Part # 429 541 A : Price \$ 200.00 : 4996338429100



POWER BRACE : FRONT - Part # 429 492 F : Price \$ 320.00 : 4996338048417 * Weight : 2.8 kg / 6.15 lbs

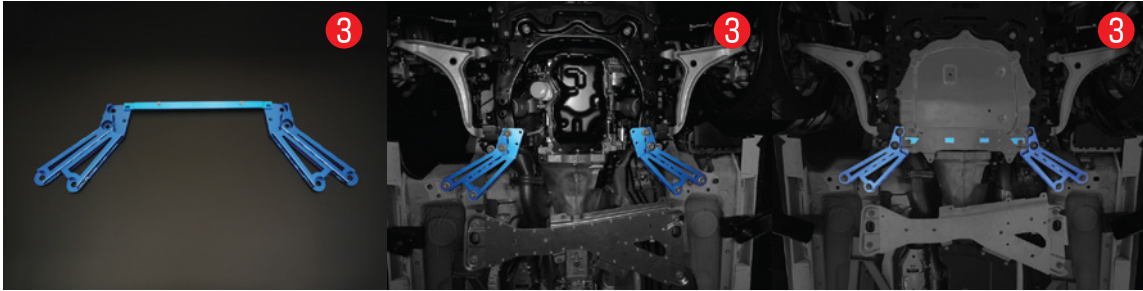

**FIGHT CHASSIS
 FLEX AND REVIVE
 OPTIMAL
 SUSPENSION
 MOVEMENT!**

POWER BRACE : FLOOR CENTER - Part # 429 492 C : Price \$ 400.00 : 4996338048424 * Weight : 4.8 kg / 10.6 lbs

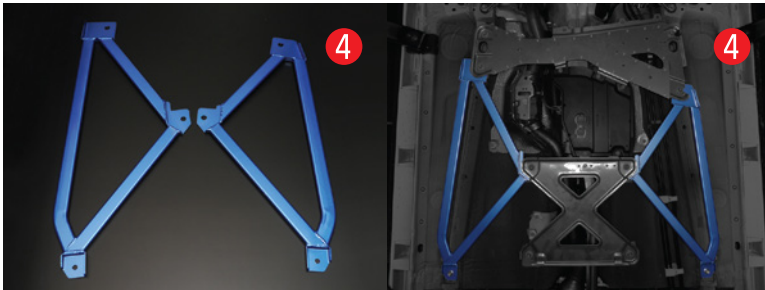

POWERBRACE

Strengthens chassis and minimizes body flex at cornering loads enabling optimal suspension movement. Similar effect as stitch welding a fatigued seasoned chassis.

- 100% bolt-on, no drilling or welding
- STKM material oval shaft (t=1.6mm)
- Designed with plenty of ground clearance

POWER BRACE : FLOOR REAR - Part # 429 492 R : Price \$ 334.00 : 4996338048431 * Weight : 3.2 kg / 7.05 lbs

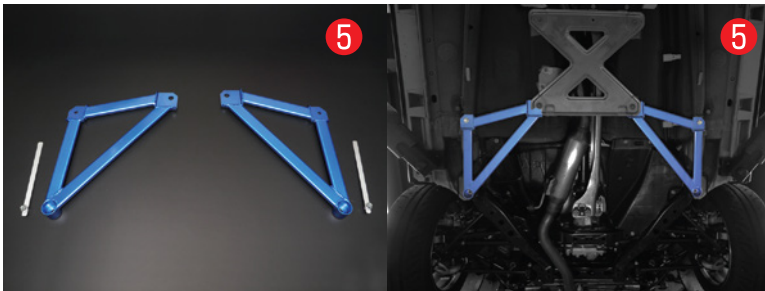

MAZDA NEW ROADSTER (ND5RC) CUSCO HIGH PERFORMANCE PARTS

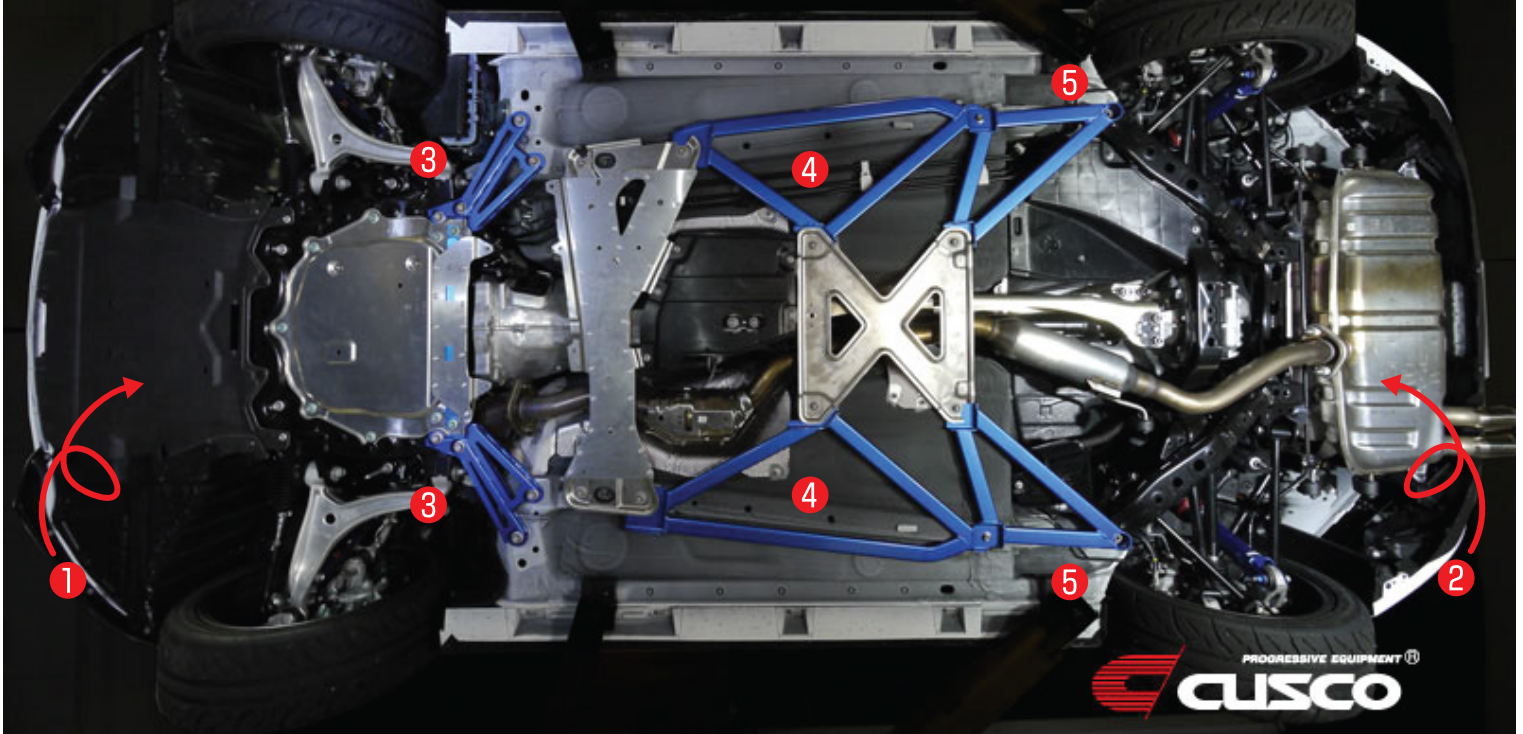

2016 MAZDA MX-5 [ND5RC]



LSD & GEARS

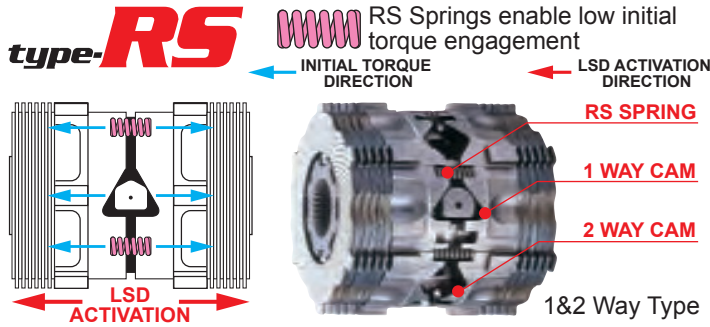

LOW INITIAL TQ, RESPONSIVE, & LONG LIFE

- Minimizes drivetrain power loss, great for underpowered vehicles
- Less chattering noise than conventional LSD systems
- Activated by RS coil springs which are designed not to lose its pressure consistency for a stable and extended performance use.
- A more direct feeling due to activation and pressure direction being on the same axis for improved throttle control.

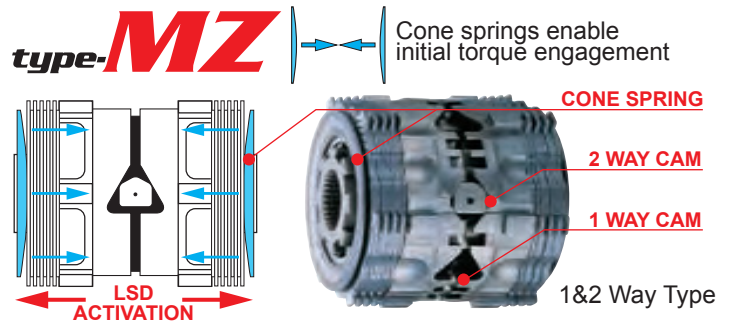

HIGH INITIAL TQ, LINEAR ENGAGEMENT

- The Type MZ is designed where the activation pressure opposes the direction of the initial torque with the utilization of cone springs.
- Available for various driveline setups that require higher initial torque setting for activation.
- Suited for high horsepowered vehicles that requires maximum traction.



Features a special flat friction clutch plates which translates to a milder initial engagement when acceleration is ON or OFF. Perfect for rear wheel drive setups in circuit situations, as well as minimizing powerloss for low horsepowered vehicles. The key is the newly designed FFD (flat friction disk) combined with outer tabbed MZ plates enables a smooth and mild effectiveness when most needed.



!!! USDM model / 2.0 L version !!!

Type- RS : LSD = Price \$1,547.00
 Part # LSD 431 F - 1 way (1 & 2 way)
 Part # LSD 431 F2 - 2 way (1 & 2 way)
 Part # LSD 431 L15 - 1.5 way (1.5 & 2 way)
 Part # LSD 431 L2 - 2 way (1.5 & 2 way)

Type- MZ : LSD = Price \$1,547.00
 Part # LSD 431 E - 1 way (1 & 2 way)
 Part # LSD 431 E2 - 2 way (1 & 2 way)
 Part # LSD 431 K15 - 1.5 way (1.5 & 2 way)
 Part # LSD 431 K2 - 2 way (1.5 & 2 way)

PINION DISTANCE COLLAR : Part # 429 029 DC Price : \$ 94.00 (msrp)
 JAN Code : 4996 3381 02553

Rear Diff mount collar :
 Part # 429 928 A : Price \$134.00
 : 4996338026866

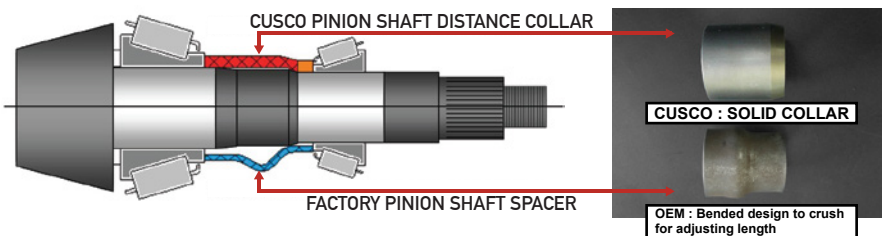

The Cusco Pinion Distance Collar is made more solid and designed to withstand the abuse of constant acceleration and deceleration, and is recommended for vehicles putting out more power & torque than the factory output.

Inside the rear differential member lies the gears and mechanisms of the limited slip differential. Once the LSD is upgraded to a clutch unit and more load and power is transferred to the rear end, factory components begin to fail. Typically, the rear pinion spacer that is located on the pinion gear shaft start to crush and cause excessive play between the pinion and ring gear. (Backlash)



PILLOW BALL BUSHINGS

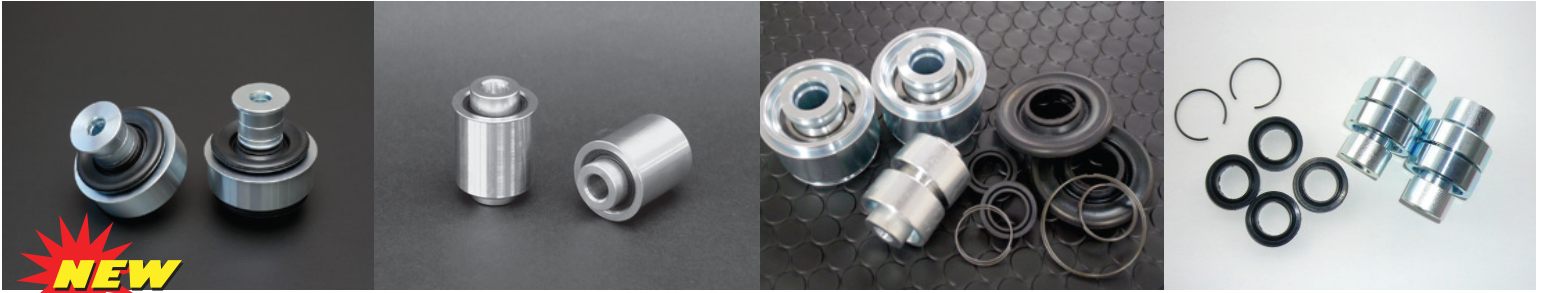

- DESCRIPTION -	- PART NUMBER -	- PRICE -	- JAN CODE -
1 : FRONT SUSPENSION : UPPER ARM * NEED 2 SETS / CAR	429 464 KV	\$ 307.00 MSRP	4996338025081
2 : FRONT SUSPENSION : LOWER ARM - FRONT SIDE	429 464 BV	\$ 307.00 MSRP	4996338025098
3 : FRONT SUSPENSION : LOWER ARM - REAR SIDE	429 464 CV	\$ 307.00 MSRP	4996338025104
4 : REAR SUSPENSION : TRAILING ARM	429 464 EV	\$ 267.00 MSRP	4996338025111
5 : REAR SUSPENSION : UPPER LATERAL LINK	429 464 JV	\$ 267.00 MSRP	4996338025128
6 : REAR SUSPENSION : LOWER LATERAL LINK	429 464 LV	\$ 267.00 MSRP	4996338025135
7 : REAR SUSPENSION : LOWER LINK	429 464 IV	\$ 267.00 MSRP	4996338025142
8 : REAR SUSPENSION : LEADING LINK	429 464 MV	\$ 267.00 MSRP	4996338025159
9 : REAR SUSPENSION : KNUCKLE TRADING LINK	429 464 NV	\$ 307.00 MSRP	4996338025166
10 : REAR SUSPENSION : KNUCKLE LOWER LATERAL LINK	429 464 HV	\$ 307.00 MSRP	4996338025173
11 : REAR SUSPENSION : KNUCKLE LEADING LINK	429 464 DV	\$ 307.00 MSRP	4996338025180

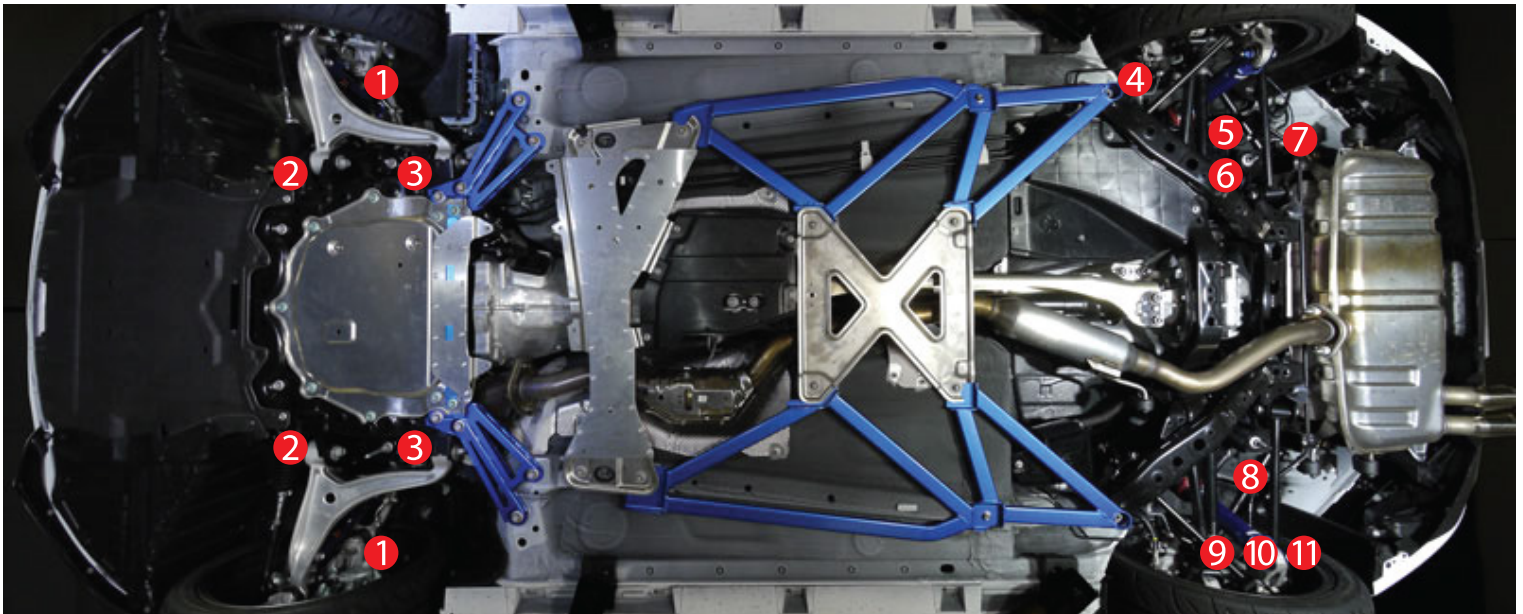



CUSCO×BRIDE COLLABORATION SEAT

COLLABORATION SEAT



Low MAX

ZETA III PLUS

- HANS Device Compatibility
- FIA Approved
- Black with Cusco Logo
- Carbon Aramid : 6.9 kg / 15 lbs
- FRP : 7.6 kg / 17 lbs



FRP Silver Shell Part No: BRD-H31HCF : \$1,080 (MSRP)

Carbon Aramid Shell Part No: BRD-H31HCR : \$2,150 (MSRP)

FO / FL / FX type Seat Rail



ZETA III : Sprot - C

FRP Black Shell Part No: BRD-F31SCF : \$900 (MSRP)

ZETA III *excludes Carbon Aramid Shell

FRP Silver Shell Part No: BRD-F31HCF : \$1,000 (MSRP)

Super Aramid Shell Part No: BRD-F31HCZ : \$1,400 (MSRP)

Carbon Aramid Shell Part No: BRD-F31HCR : \$2,000 (MSRP)

ZETA III : Typer - L *excludes Carbon Aramid Shell

FRP Silver Shell Part No: BRD-FL1HCF : \$1,150 (MSRP)

Super Aramid Shell Part No: BRD-FL1HCZ : \$1,500 (MSRP)

Carbon Aramid Shell Part No: BRD-FL1HCR : \$2,200 (MSRP)

ZETA III : Typer - XL *excludes Carbon Aramid Shell

FRP Silver Shell Part No: BRD-F91HCF : \$1,150 (MSRP)

Super Aramid Shell Part No: BRD-F91HCZ : \$1,500 (MSRP)

Carbon Aramid Shell Part No: BRD-F91HCR : \$2,200 (MSRP)

FO / FL / FX type Seat Rail (XL type Seat Rail)



STRADIA II

- Steel Frame Structure
- Luxury Suede / Fire Retardant
- Low Cushion, Stitchless
- Silver FRP Construction
- Weight : 14 kg / 31 lbs

Standard Cushion Part No: BRD-G33SCF : \$1,800 (MSRP)

Lowered Cushion Part No: BRD-G23SCF : \$1,800 (MSRP)

STRADIA II : Type - XL

Standard Cushion Part No: BRD-G55SCF : \$2,150 (MSRP)

GIAS II

High Side Bolster Part No: BRD-G32SCF : \$1,800 (MSRP)

RO / LR type Seat Rail

Super Seat Rail : RO type

RO type Seat Rail : Price \$220.00

Part #
 Driver side (Left) : BRDS-R006RO
 Passenger side (Right) : BRDS-R005RO



Super Seat Rail : LR type

LR type Seat Rail : Price \$225.00

Part #
 Driver side (Left) : BRDS-R006LR
 Passenger side (Right) : BRDS-R005LR



Super Seat Rail : FO type

FO type Seat Rail : Price \$250.00

Part #
 Driver side (Left) : BRDS-R006FO
 Passenger side (Right) : BRDS-R005FO



DIGO III LIGHT

- Available with CRUZ (Armrest) Option
- Touring recliner
- Anatomically ergonomic seating
- Weight : 15.2 kg / 33 lbs

Part No: BRD-D45ACS : \$1,000 (MSRP)

DIGO III LIGHT - CRUZ

Part No: BRD-D44ACS : \$1,050 (MSRP)

CRUZ OPTIONAL ARM REST

Right Side Part No: BRDA-P51ANN : \$75 (MSRP)

Left Side Part No: BRDA-P52ANN : \$75 (MSRP)

EUROSTER II

- Available with CRUZ (Armrest) Option
- Fireproof Material
- Weight : 16.1 kg / 35.5 lbs (one arm rest)

Part No: BRD-E32ACN : \$1,100 (MSRP)

EUROSTER II - CRUZ

Part No: BRD-E54ACN : \$1,150 (MSRP)

CRUZ OPTIONAL ARM REST

Right Side Part No: BRDA-P51ANN : \$75 (MSRP)

Left Side Part No: BRDA-P52ANN : \$75 (MSRP)

MO type Seat Rail : \$240 (MSRP)

Super Seat Rail : LF type

LF type Seat Rail : Price \$250.00

Part #
 Driver side (Left) : BRDS-R006LF
 Passenger side (Right) : BRDS-R005LF



Super Seat Rail : FX type

LF type Seat Rail : Price \$275.00

Part #
 Driver side (Left) : BRDS-R006FX
 Passenger side (Right) : BRDS-R005FX



(* 1)
 A shoulder part and a door interfere depending on matching with a vehicle type.