

## VEHICLE APPLICATION PRODUCT GUIDE

MITSUBISHI LANCER EVOLUTION X (CZ4A)

MITSUBISHI LANCER (CY4A)



**MITSUBISHI EVO X (CZ4A)**



**MITSUBISHI LANCER (CY4A)**

**MITSUBISHI GALANT FORTIS (CY4A)**

**MITSUBISHI RALLIART (CY4A)**

- ▶ **SUSPENSION**
- ▶ **SWAY BAR**
- ▶ **STRUT BAR**
- ▶ **PILLOWBALL MOUNT**
- ▶ **CLUTCH**
- ▶ **LIMITED SLIP DIFFERENTIAL**
- ▶ **LIMITED SLIP DIFFERENTIAL (PRO)**
- ▶ **ROLL CAGE**
- ▶ **COMPETITION PARTS**
- ▶ **ENGINE PARTS**
- ▶ **ADDITIONAL PARTS**

**Street Series Adjustable Suspension Coilover Kit**

**NEW LOW PRICE**

**street ZERO A**

**40 WAY**

**FULL HEIGHT ADJUST**

**NEW LOW PRICE**

**street A**

**40 WAY**

**NEW LOW PRICE**

**street zero**

**FULL HEIGHT ADJUST**

**Set the shocks from the driver seat**

**e-Con2**

**40 WAY ELECTRONIC DAMPER CONTROL e-Con2**

Street-A Kit	:00B 60J 1012
Street ZERO-A Kit	:00B 60J 1014
Touring A Kit	:00B 60J 1012
\$634 (MSRP)	

- Adjust 40way of front & rear shocks dampening
- Switch between vertical & horizontal display
- Record and save up to 4 shock setting profiles
- 7 different illumination colors to choose from
- G Sensor feature \$131 (Sold separately)

**40 Way Adjust Step Motor**

**G Sensor**

LANCER EVOLUTION	PRODUCT	CZ4A (EVO X)		CY4A (LANCER)	
		ITEM	MSRP	ITEM	MSRP
COILOVER SUSPENSION	STREET ZERO (NORMAL)	566 61P CN	\$ 1,480.00	542 61P CB (UPPER LESS)	\$ 1,280.00
	STREET ZERO : CP2 OPTION (PILLOW)	566 61P CP	\$ 1,747.00		
	STREET A	566 61J CB	\$ 1,230.00	542 61J CB (UPPER LESS)	\$ 1,100.00
	ZERO A (NORMAL)	566 61N CN	\$ 1,600.00	542 61N CN	\$ 1,600.00
	ZERO A : CP2 OPTION (PILLOW)	566 61N CP	\$ 1,867.00		
	ZERO 3S	566 63S CN	\$ 2,280.00		
	ZERO 3R	566 63R CP	\$ 2,480.00		
	ZERO 3X	566 63X CP	\$ 4,180.00		
	ZERO 3G (GRAVEL)	566 63C LB0	\$ 2,380.00		
	ZERO 3G (TARMAC)	566 63C SB0	\$ 2,180.00		

**SPORT PERFORMANCE MONOTUBE SHOCK ABSORBER "SPORT" SERIES MONOTUBE SHOCK ABSORBER "COMPETITION" SERIES**



**MONOTUBE SHOCKS** Pillow Upper : Front  
**24x3 WAY ADJUST** Pillow Upper : Rear

- Full height adjustable coilover structure
- 3 way dampening precise adjustment
- Rebound- 24 way, Compression: Hi- 24way + Low 24 way
- Mono-tube inverted shock layout
- External reservoir for increased capacity
- Front: pillowball camber adjustable
- Rear: pillowball upper mount



**MONOTUBE SHOCKS** Pillow Upper : Front  
**24 WAY ADJUST** Pillow Upper : Rear

- Full height adjustable coilover structure
- 24 way adjustable needle valve shocks
- Mono-tube inverted shock layout
- Front: pillowball camber adjustable
- Rear: pillowball upper mount



**MONOTUBE SHOCKS** Pillow Upper : Front  
**24 WAY ADJUST** HD Rubber Upper : Rear

- Full height adjustable coilover structure
- 24 way adjustable needle valve shock absorber
- Mono-tube inverted shock layout
- Front: pillowball camber adjustable
- Rear: HD rubber upper mount



**CUSCO ANTI-SWAY BARS**

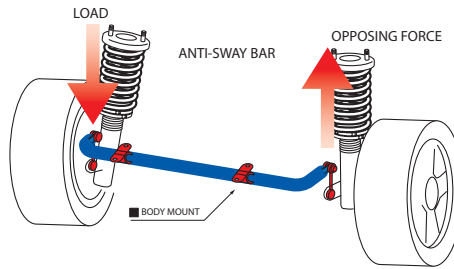

LANCER EVOLUTION	PRODUCTS	CZ4A (EVO X)			CY4A (LANCER)		
		ITEM	TYPE	MSRP	ITEM	TYPE	MSRP
SWAY BAR	FRONT	566 311 A27	27mm OD	\$ 374.00	872 311 A24	24mm OD	\$ 334.00
		566 311 A23	23mm Rally / Dirt ver	\$ 374.00			
	REAR	566 311 B25	25mm OD	\$ 334.00	542 311 B22	22mm OD (test fit pending)	\$ 294.00
		566 311 B21	21mm Rally / Dirt ver	\$ 334.00			
F-ADJ BRACKET	560 315 A	Front	\$ 64.00				

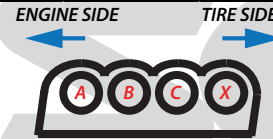

- Effectiveness of the sway bar can be adjusted
- Use with CUSCO Sway Bar for finer adjustment choices
- Best bang for the buck

**A = 86% (soft)**  
**B = 100% (factory)**  
**C = 116% (hard)**  
**X = NOT USED**

**Front Sway Bar Adjustment Bracket**  
**Part No: 560 315 A**  
**Spec: 3 Levels of Adjustment**  
**Can be used with OEM sway bar**  
**MSRP: \$374.00**

**LOWER ARM BAR, SHIFT LINKAGE COLLAR, REAR LATERAL LINK**



LOWER ARM BAR VERSION 2  
PART NO: 566 477 A  
CZ4A EVO X & CY4A LANCER

SHIFT LINKAGE COLLAR  
PART NO: 566 940 A  
CZ4A EVO X & CY4A LANCER

REAR LATERAL LINK  
PART NO: 566 474 B  
CZ4A EVO X

LANCER EVOLUTION	PRODUCTS	CZ4A (EVO X)		CY4A (LANCER)	
		ITEM	MSRP	ITEM	MSRP
LATERAL LINK - REAR	PILLOW	566 474 B	\$ 720.00		
SHIFT LINKAGE COLLAR		566 940 A	\$ 131.00	566 940 A	\$ 131.00
LOWER ARM BAR	VER. 2	566 477 A	\$ 200.00	566 477 A	\$ 200.00

**STRUT BARS & POWER BRACES**



<b>LANCER EVOLUTION</b>	<b>PRODUCTS</b>	<b>CZ4A (EVO X)</b>		<b>CY4A (LANCER)</b>	
		<b>ITEM</b>	<b>MSRP</b>	<b>ITEM</b>	<b>MSRP</b>
<b>STRUT TOWER BRACE</b>	HYBRID TYPE FRONT (urethane bushings)	566 542 A	\$ 240.00	542 542 A	\$ 240.00
	OS - FRONT	566 540 A	\$ 200.00	542 540 A	\$ 200.00
	OS - REAR	566 541 A	\$ 334.00	542 541 A	\$ 200.00
<b>POWER BRACE</b>	FLOOR FRONT	566 492 FF	\$ 294.00	566 492 FF	\$ 294.00
	FLOOR CENTER	566 492 C	\$ 374.00	566 492 C	\$ 374.00
	FLOOR REAR SIDE	566 492 FR	\$ 174.00		
	REAR MEMBER	566 492 RM	\$ 294.00		
	REAR MEMBER REAR	566 492 RR	\$ 187.00	566 492 RR	\$ 187.00
	REAR MEMBER SIDE	566 492 RS	\$ 174.00		

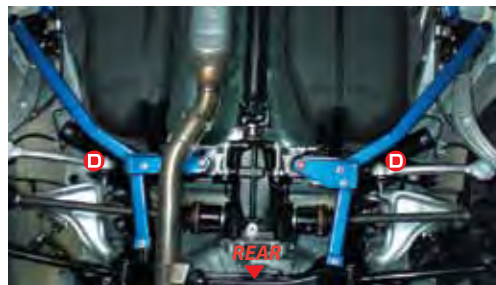
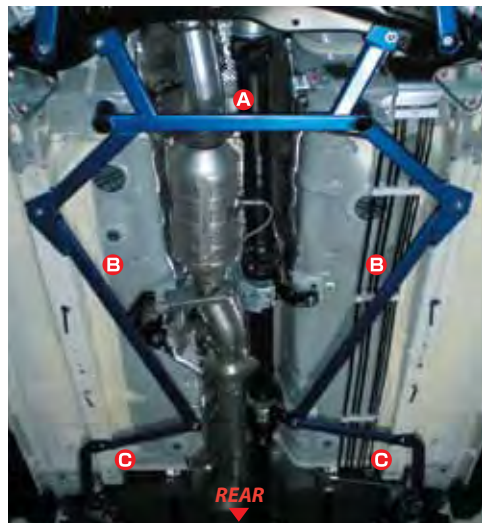

**LANCER EVO X (CZ4A)**

- A** FLOOR FRONT
- B** FLOOR CENTER
- C** FLOOR REAR SIDE
- D** REAR MEMBER
- E** REAR MEMBER REAR
- F** REAR MEMBER SIDE

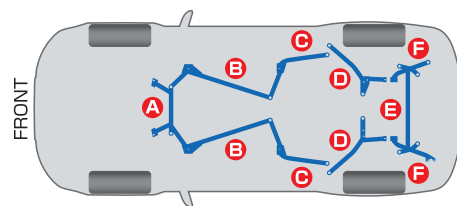

**PILLOWBALL UPPER MOUNT**

**ADJUSTABLE PILLOWBALL UPPER MOUNT**



Pillowball upper camber plates provide fine adjustment from positive to negative camber on various suspension systems. Made from 2017S Duralumin with 6mm thick plates and custom pillow nut and collar.

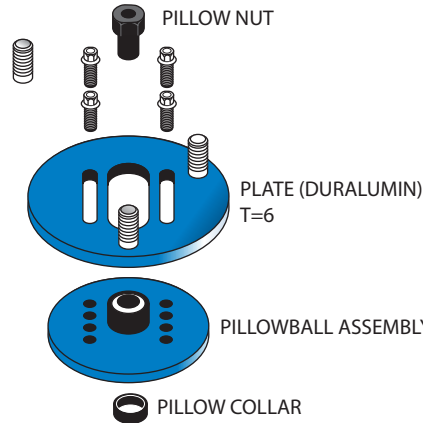
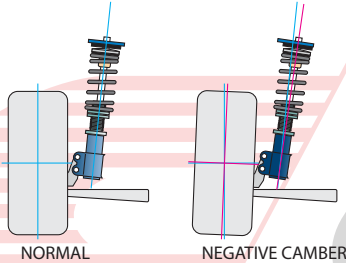

**GRAVEL / RALLY SPEC PILLOW UPPER MOUNT**

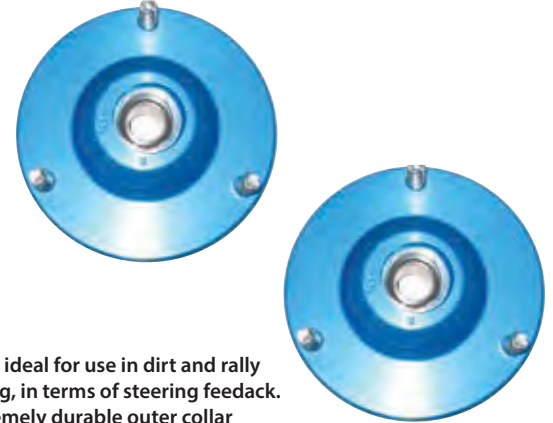

Most ideal for use in dirt and rally racing, in terms of steering feedback. Extremely durable outer collar. Easy pillowball replacement from MBWT18 to MBWT22. Complies with various manufacturer suspension units including factory.

LANCER EVOLUTION	PRODUCTS	CZ4A (EVO X)	
		ITEM	MSRP
PILLOWBALL UPPER MOUNT	FRONT ADJUSTABLE CAMBER	566 410 A	\$ 320.00
	FRONT ADJUSTABLE - CARROSSER	566 440 CA	\$ 360.00
	FRONT RIGID - GRAVEL SPEC	566 445 A	\$ 467.00

**PILLOWBALL BUSHING**

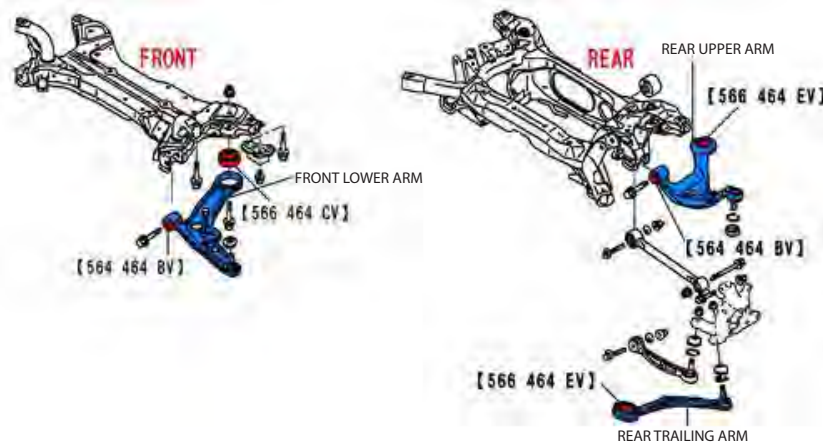

LANCER EVOLUTION	PRODUCTS	CZ4A (EVO X)		CY4A (LANCER)	
		ITEM	MSRP	ITEM	MSRP
PILLOWBALL BUSHING (SET)	FRONT LOWER ARM - FRONT SIDE	564 464 BV	\$ 307.00		
	FRONT LOWER ARM - REAR SIDE	566 464 CV	\$ 520.00		
	TRAILING ARM	566 464 EV	\$ 520.00		
	REAR UPPER ARM - FRONT SIDE	564 464 BV	\$ 307.00		
	REAR UPPER ARM - REAR SIDE	566 464 EV	\$ 520.00		

**CLUTCH & FLYWHEEL SETS**

**SINGLE CLUTCH SYSTEM**

**COPPER SINGLE SET**

**METAL DISK SET**



Lightweight Aluminum Clutch Cover  
 11800N/f (1200kg/f) Holding Pressure

**THIN METAL CLUTCH + COVER**

**TWIN METAL SYSTEM**

**COPPER TWIN SYSTEM**



Ultra-Lightweight Clutch & Cover  
 9800N/f (1000kg/f) Holding Pressure

Lightweight Aluminum Clutch Cover  
 9800N/f (1000kg/f) Holding Pressure

Lightweight Aluminum Clutch Cover  
 9800N/f (1000kg/f) Holding Pressure

<b>LANCER EVOLUTION</b>	<b>PRODUCTS</b>	<b>CZ4A (EVO X)</b>		<b>CY4A (LANCER)</b>	
		<b>ITEM</b>	<b>MSRP</b>	<b>ITEM</b>	<b>MSRP</b>
<b>CLUTCH / FLYWHEEL</b>	COPPER SINGLE DISC	00C 022 R560	\$ 372.00	00C 022 R560	\$ 372.00
	COPPER CLUTCH SET	560 022 F	\$ 771.00	560 022 F	\$ 771.00
	HP COPPER CLUTCH SET	562 022 F	\$ 810.00	562 022 F	\$ 810.00
	METAL DISC	00C 022 C209SM	\$ 428.00	00C 022 C209SM	\$ 428.00
	METAL CLUTCH SET	560 022 G	\$ 823.00	560 022 G	\$ 823.00
	HP METAL CLUTCH SET	562 022 G	\$ 862.00	562 022 G	\$ 862.00
	CLUTCH COVER 880~1050	00C 022 B560	\$ 486.00	00C 022 B560	\$ 486.00
	CLUTCH COVER 1200~1360	00C 022 B560N	\$ 528.00	00C 022 B560N	\$ 528.00
	THIN METAL CLUTCH DISC	560 022 C	\$ 428.00	560 022 C	\$ 428.00
	THIN METAL CLUTCH COVER	560 022 B	\$ 571.00	560 022 B	\$ 571.00
	CHRO-MOLY FLYWHEEL	560 023 A	\$ 654.00	560 023 A	\$ 654.00
	SINGLE CLUTCH SET	560 022 HP	\$ 1,799.00	560 022 HP	\$ 1,799.00
	- CLUTCH COVER ASSY	00C 022 CH01SCUI	\$ 643.00	00C 022 CH01SCUI	\$ 643.00
	- PRESSURE PLATE	-	-	-	-
	- CLUTCH DISC	00C 022 DH03DI	\$ 428.00	00C 022 DH03DI	\$ 428.00
	- FLYWHEEL	00C 022 FH01	\$ 714.00	00C 022 FH01	\$ 714.00
	- BOLT SET	00C 022 BS03	\$ 15.00	00C 022 BS03	\$ 15.00
	- FLYWHEEL BOLT SET	USE OEM PART	-	USE OEM PART	-
	- SLEEVE & BEARING	-	-	-	-
	COPPER TWIN CLUTCH	560 022 CP	\$ 2,640.00	560 022 CP	\$ 2,640.00

# CUSCO LSD

## Limited Slip Differentials

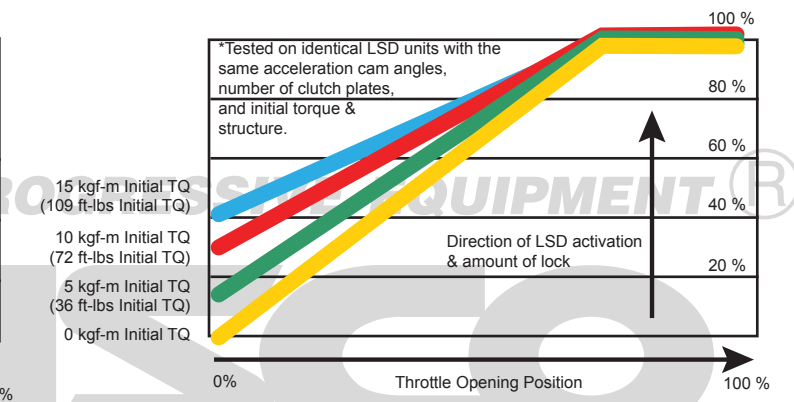
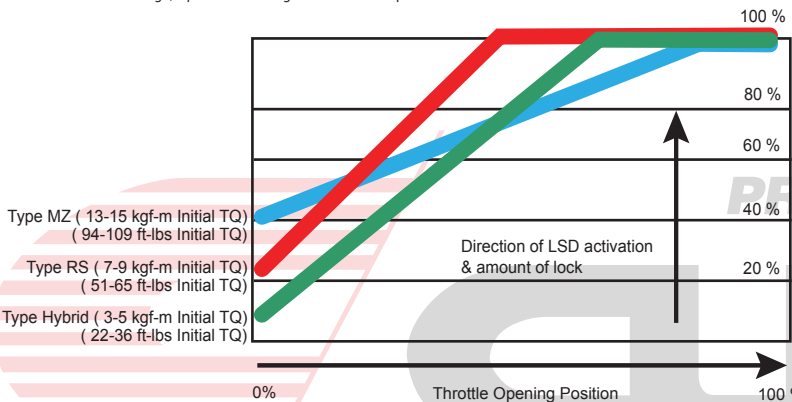
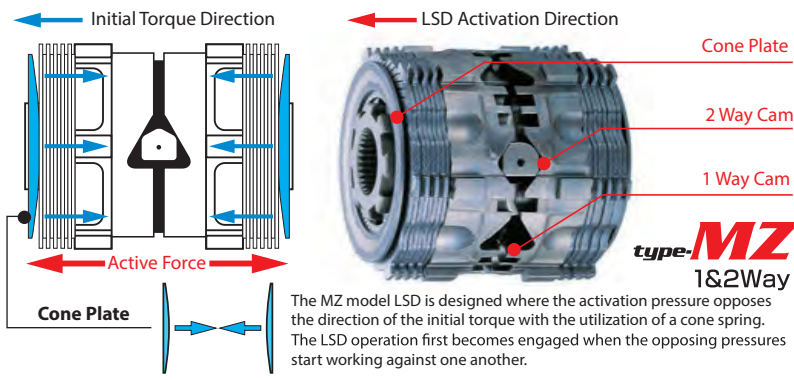
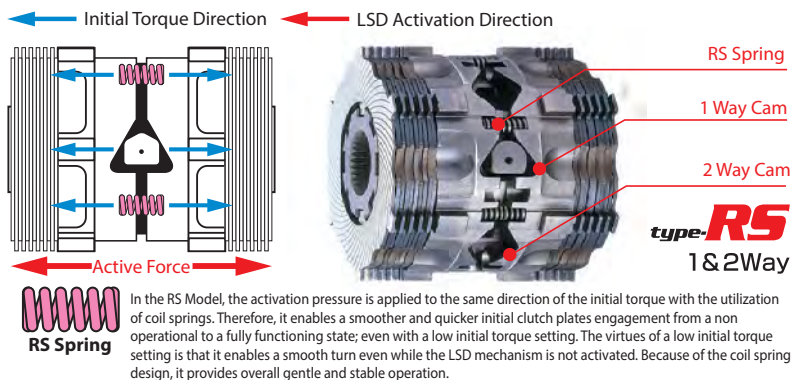

The primary difference between RS, MZ, and Hybrid units is the applied initial torque amount and the activation direction.

### Initial Torque and LSD Activation Direction

The lower the initial torque setting, the more ineffective the unit may feel. This is because the initial operation is set at a low amount.

### THE CAM ANGLE

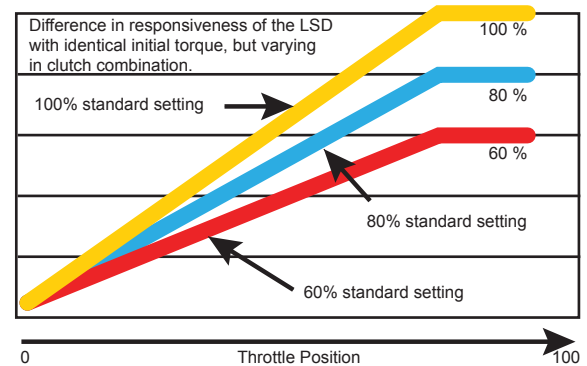
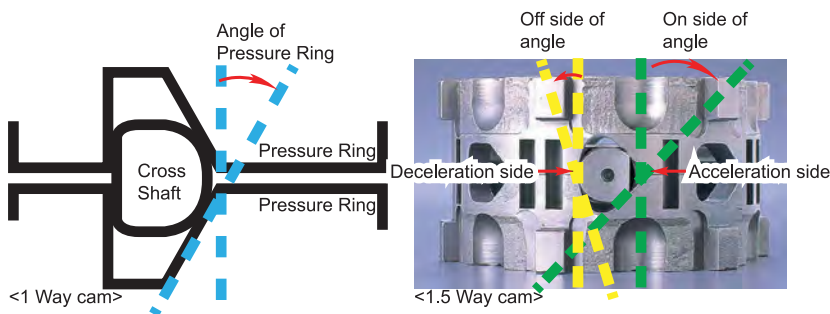

## LANCER EVOLUTION LIMITED SLIP DIFFERENTIAL

MODEL	T/M	POSITION	OEM DIFF	CAM	CUSCO L.S.D. TYPE - RS			MSRP	CUSCO L.S.D. TYPE - MZ			MSRP		
					INITIAL SET UP				INITIAL SET UP					
					1 WAY	1.5 WAY	2 WAY		1 WAY	1.5 WAY	2 WAY			
CZ 4A / CY 4A	MT / SST	F	ACD	1 WAY	LSD 453 F		\$ 1,520.00	LSD 453 A			\$ 1,467.00			
				1 & 1.5 WAY	LSD 453 C	LSD 453 C15		LSD 453 B	LSD 453 B15					
				1 WAY	LSD 454 F			\$ 2,480.00	LSD 454 A			\$ 2,347.00		
				1 & 1.5 WAY	LSD 454 C	LSD 454 C15			LSD 454 B	LSD 454 B15				
				1 & 2 WAY	LSD 141 F				\$ 1,400.00	LSD 141 A				\$ 1,374.00
				1.5 & 2 WAY		LSD 141 L15				LSD 141 L2			LSD 141 A2	
	1 WAY	LSD 141 FG												
	1 WAY	LSD 141 FR												
	1 & 2 WAY	LSD 452 F		\$ 1,507.00										
	1.5 & 2 WAY		LSD 452 L15		LSD 452 L2									

## CUSCO LSD *Limited Slip Differentials*

# PRO Adjust LSD

For professional & competition use, where even the slightest milliseconds count.  
 Specific cam angle and timing adjustment to a precise level. The larger the cam angle, the faster and stronger the LSD locks.  
 LSD can be modified to 1, 1.5, or 2 way by changing the cam chips.  
 The limited slip lock up timing also adjustable.

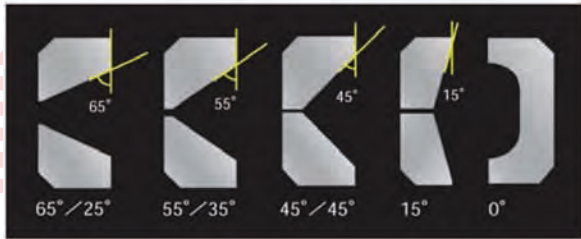
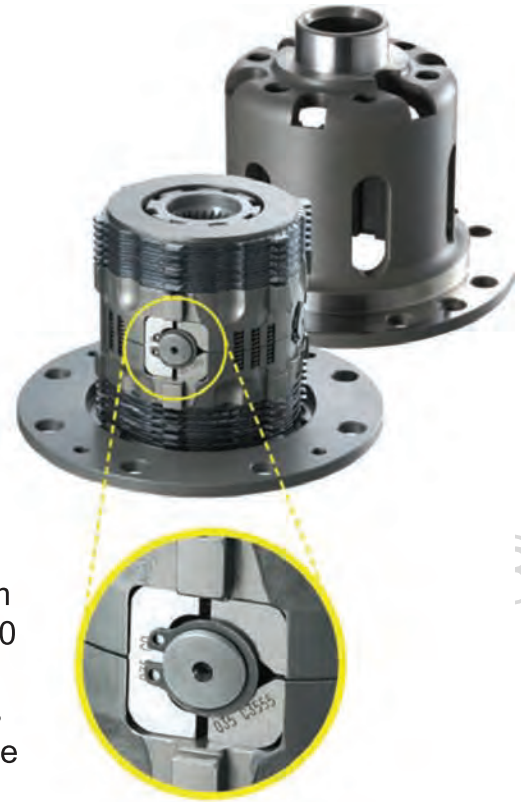

Cam angle is available from 0, 15, 25, 35, 45, 55, and 60 degree.  
 0 and 15 degree cam chips are for acceleration side use only.

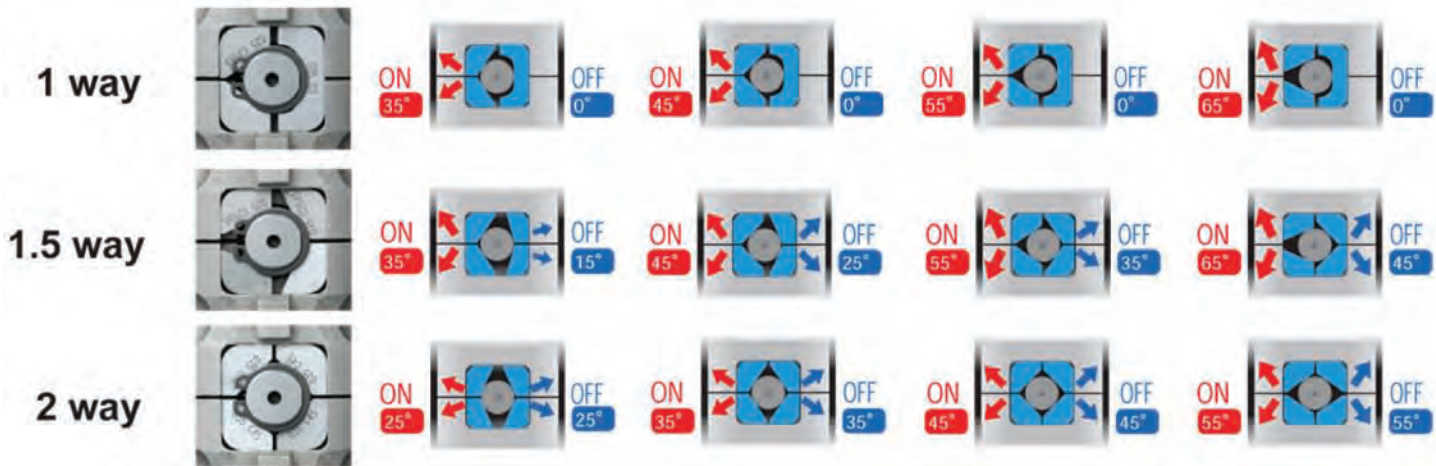

MODEL	TRANSMISSION	DESIGNATION	OEM DIFF	TYPE RS		TYPE MZ	
EVO X CZ4A	MT/SST	Front	ACD	LSD 454 R	\$3,000	-	-
		Rear	No AYC	LSD 141 R	\$1,880	LSD 141 S	\$1,880
Lancer CY4A	MT/SST	Front	ACD	LSD 454 R	\$3,000	-	-
		Rear	No AYC	LSD 141 R	\$1,880	LSD 141 S	\$1,880



**ROLLCAGE**



**CUSCO D1 SPEC ROLLCAGE 40MM OD CHRO-MOLY**

WEIGHT / 10.5kg	WEIGHT / 12.8kg	WEIGHT / 18.6kg	WEIGHT / 20.9kg	WEIGHT / 23.2kg
4 POINT	5 POINT	6 POINT	7 POINT	8 POINT



**CUSCO SAFETY21 ROLLCAGE 40MM OD STEEL CONSTRUCTION**

WEIGHT / 13.0kg	WEIGHT / 16.0kg	WEIGHT / 24.0kg	WEIGHT / 27.0kg	WEIGHT / 30.0kg
4 POINT	5 POINT	6 POINT	7 POINT	8 POINT
9 POINT	10 POINT	11 POINT	12 POINT	13 POINT
				15 POINT

**DASH THROUGH**



FIA APPROVED ROLL CAGES ALSO AVAIL. PLEASE INQUIRE

**EVOLUTION X CZ4A ROLLCAGES**

POINT	ROLL CAGE		STEEL / SAFETY21		CHRO-MOLY / D1	
	PASSENGER	FRONT TYPE	ITEM	MSRP	ITEM	MSRP
4 PT	2	N/A	566 270 C20	\$ 534.00	566 261 C	\$ 600.00
	5	N/A	566 270 A20	\$ 534.00	566 261 A	\$ 600.00
5 PT	2	N/A	566 270 D20	\$ 667.00	566 261 D	\$ 774.00
	5	N/A	566 270 K20	\$ 667.00	566 261 K	\$ 774.00
6 PT	2	ESCAPE	566 270 E20	\$ 867.00	566 261 E	\$ 960.00
	2	THROUGH	566 290 E20	\$ 867.00	566 265 E	\$ 960.00
	5	ESCAPE	566 270 B20	\$ 867.00	566 261 B	\$ 960.00
7 PT	2	THROUGH	566 290 B20	\$ 867.00	566 265 B	\$ 960.00
	2	ESCAPE	566 270 F20	\$ 1,000.00	566 261 F	\$ 1,134.00
	2	THROUGH	566 290 F20	\$ 1,000.00	566 265 F	\$ 1,134.00
	5	ESCAPE	566 270 L20	\$ 1,000.00	566 261 L	\$ 1,134.00
8 PT	2	THROUGH	566 290 L20	\$ 1,000.00	566 265 L	\$ 1,134.00
	2	ESCAPE	566 270 G20	\$ 1,134.00	566 261 G	\$ 1,334.00
	2	THROUGH	566 290 G20	\$ 1,134.00	566 265 G	\$ 1,334.00
9 PT	2	ESCAPE	566 270 W9	\$ 1,160.00		
	2	THROUGH	566 290 W9	\$ 1,160.00		
10 PT	2	ESCAPE	566 270 W10	\$ 1,294.00		
	2	THROUGH	566 290 W10	\$ 1,294.00		
12 PT	2	ESCAPE	566 270 W12	\$ 1,560.00		
	2	THROUGH	566 290 W12	\$ 1,560.00		
13 PT	2	ESCAPE	566 270 W13	\$ 1,694.00		
	2	THROUGH	566 290 W13	\$ 1,694.00		

**ADDITIONAL COMPONENTS**

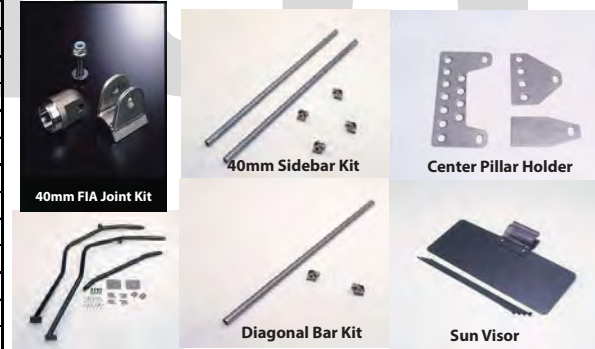

**DASH ESCAPE**

**ADD-ON BARS**



**SIDE REINFORCEMENT BARS**

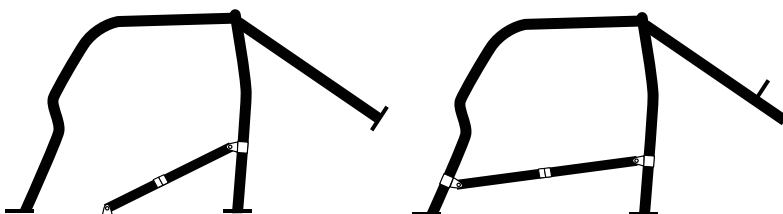

**FLOOR TYPE**

**PIPE - PIPE TYPE**



**Aluminum Bolt-On Bar**

**Steel Bolt-On Bar**

**COMPETITION PARTS**



**ACRYLIC WINDOW SET**  
DOOR = 3mm  
QUARTER = 3mm  
REAR = 3mm

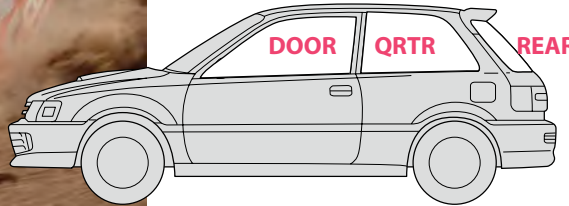

LANCER EVOLUTION	PRODUCTS	CZ4A (EVO X)		CY4A (LANCER)	
		ITEM	MSRP	ITEM	MSRP
GUARD PANEL	FULL GUARD - DIRT TRACK	566 213 A	\$ 760.00		
	WRC GUARD - STANDARD	565 211 WS	\$ 1,467.00		
	WRC GUARD - HEAVY DUTY	565 211 WH	\$ 2,134.00		
	FLOOR GUARD	566 214 A	\$ 480.00		
	TANK GUARD	566 215 A	\$ 294.00		
	JOINT GUARD	566 217 A	\$ 160.00		
	DIFF GUARD	566 219 A	\$ 174.00		
REAR VENT PANEL	REAR RALLY VENT PANEL	566 828 A	\$ 307.00	566 828 A	\$ 307.00
ACRYLIC WINDOW	1 SET (DOOR, QTR, REAR)	566 800 A	\$ 1,734.00	566 800 A	\$ 1,734.00

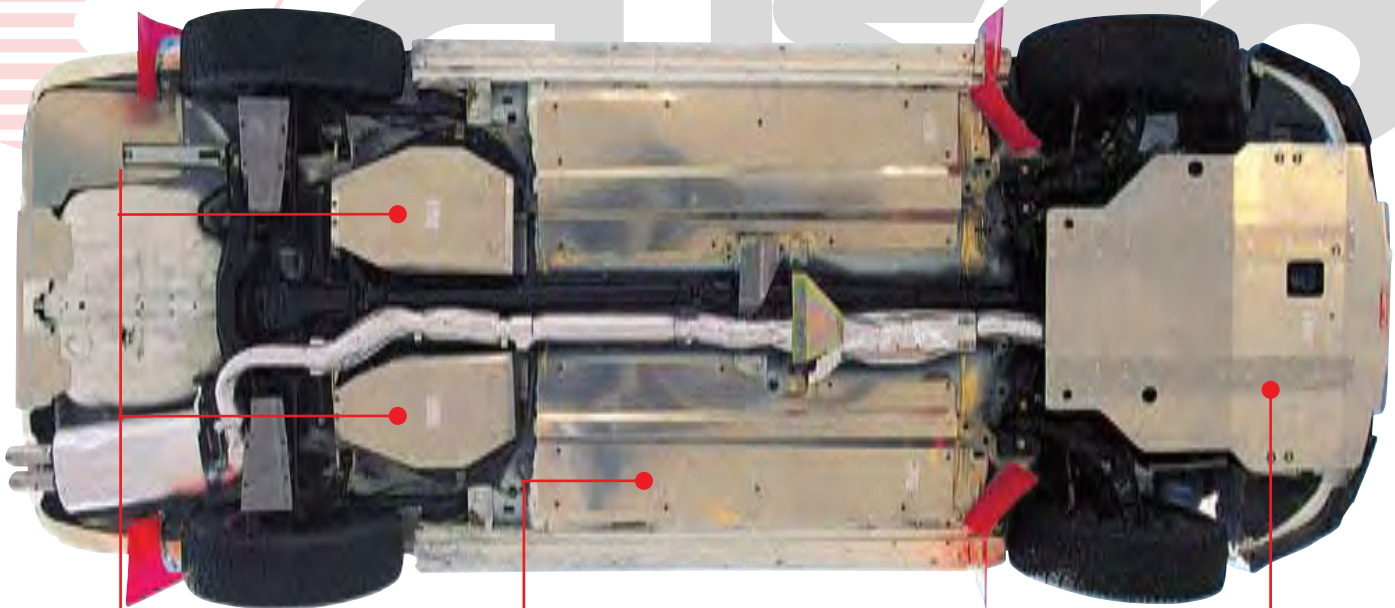

**TANK GUARD**  
2mm thick 52S Duralumin fuel tank guards

**FLOOR GUARD**  
3mm thick 52S Duralumin floor panel guards

**WRC UNDERGUARD**  
Standard Type=5mm thickness  
Heavy Duty Type=5mm+5mm Ribbed  
Both made from 17S Duralumin  
\*Heavy Duty Type Shown

**FULL GUARD (DIRT)**  
5mm thick 17S Duralumin combined with 3mm 52S Duralumin under engine guard

**ENGINE PARTS**

**ENGINE MOUNT (CZ4A)**



Made from CUSCO Hard Rubber.  
 Improves engine response and overall throttle feel.

**CLUTCH MASTER CYLINDER SUPPORT PLATE**



Reinforces the factory plastic master cylinder.  
 Improves clutch feel and operation.

**PROGRESSIVE EQUIPMENT®**



LANCER EVOLUTION	PRODUCTS	CZ4A (EVO X)		CY4A (LANCER)	
		ITEM	MSRP	ITEM	MSRP
ENGINE PARTS	OIL CATCH TANK STREET (0.6L)	566 009 A	\$ 131.00		
	OIL CATCH TANK COMPETITION - UNIVERSAL (2L)	00A 010 A	\$ 187.00	00A 010 A	\$ 187.00
	OIL CATCH TANK COMPETITION - UNIVERSAL (3L)	00A 011 A	\$ 200.00	00A 011 A	\$ 200.00
	OIL CATCH TANK SIDE MOUNT - UNIVERSAL (0.6L)	00B 009 JB	\$ 131.00	00B 009 JB	\$ 131.00
	OIL CATCH TANK SEPARATOR TYPE - UNIV. (2L)	00B 010 A	\$ 240.00	00B 010 A	\$ 240.00
	RADIATOR CAP (1.27 Bar, 126.5 Deg. C)	00B 050 A13	\$ 34.00	00B 050 A13	\$ 34.00
	BATTERY CUT OFF SWITCH (JIS +17mm, -15mm)	00B 742 A	\$ 54.00	00B 742 A	\$ 54.00
	BATTERY CUT OFF SWITCH (DIN +13mm, -11mm)	00B 742 B	\$ 54.00	00B 742 B	\$ 54.00
	BATTERY CUT OFF SWITCH SET (Turn Type)	00B 740 A	\$ 214.00	00B 740 A	\$ 214.00
	BATTERY CUT OFF SWITCH SET (Magnet Type)	00B 741 A	\$ 200.00	00B 741 A	\$ 200.00
	SPORTS OIL FILTER (68mm x H65mm M20-P1.5)	00B 001 C	\$ 34.00	00B 001 C	\$ 34.00
EXHAUST MUFFLER HD RING	RUBBER MUFFLER RING - HEAVY DUTY BLACK	A160 RM004	\$ 12.00	A160 RM004	\$ 12.00
	RUBBER MUFFLER RING - HEAVY DUTY BLUE	A160 RM004B	\$ 12.00	A160 RM004B	\$ 12.00

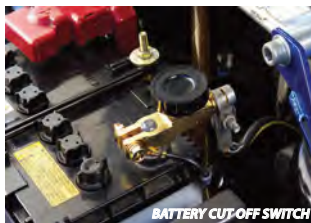
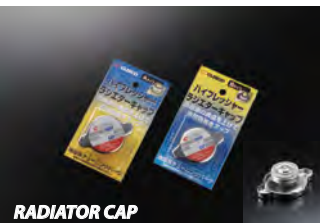

**ADDITIONAL PRODUCTS**

**HOOD PIN SERIES**

- ① Blue Aluminum Hood Pin    ③ Hood Pin with Lock
- ② Silver Aluminum Hood Pin    ④ Spring Trunk Hook



LANCER EVOLUTION	PRODUCTS	CZ4A (EVO X)		CY4A (LANCER)	
		ITEM	MSRP	ITEM	MSRP
HOOD PIN	BLUE ALUMINUM	00B 817 AL	\$ 54.00	00B 817 AL	\$ 54.00
	BLACK ALUMINUM	00B 817 AB	\$ 54.00	00B 817 AB	\$ 54.00
	SILVER ALUMINUM	00B 817 A	\$ 51.00	00B 817 A	\$ 51.00
	HOOD PIN W/ LOCK	A517 C402	\$ 80.00	A517 C402	\$ 80.00
	SPRING TRUNK HOOK	00B 818 A	\$ 34.00	00B 818 A	\$ 34.00

**DAMPER ADJUSTMENT DIAL**

**SHIFT KNOB**

**SPIN TURN KNOB**

**Tow Hook**  
(Steel Material, Orange Color)

**SHORT ANTENNA**  
(carbon type outer)

**SHORT ANTENNA**  
(black type outer)

LANCER EVOLUTION	PRODUCTS	CZ4A (EVO X)		CY4A (LANCER)	
		ITEM	MSRP	ITEM	MSRP
DRIFT KNOB	DRIFT KNOB SILVER	00B 014 AA	\$ 27.00	00B 014 AA	\$ 27.00
	DRIFT KNOB BLUE	00B 014 AL	\$ 27.00	00B 014 AL	\$ 27.00
	DRIFT KNOB RED	00B 014 AR	\$ 27.00	00B 014 AR	\$ 27.00
SHIFT KNOB	SHIFT KNOB MITSUBISHI	00B 760 3WW	\$ 40.00	00B 760 3WW	\$ 40.00
SHORT ANTENNA	CARBON	00B 809 AC	\$ 33.34	00B 809 AC	\$ 33.34
	BLACK	00B 809 AB	\$ 33.34	00B 809 AB	\$ 33.34
TOW HOOK	UNIVERSAL	00A 016 AJ	\$ 107.00	00A 016 AJ	\$ 107.00